

FIRE WALL

Security System

F9/F10 USER MANUAL



INSTALLATION & START-UP MANUAL



Important start-up tips

Device setup method:

In the SIM card supporting security systems of Firewall Co., the device action is automatically conducted following the entry of the ADMIN phone number.

Sometimes due to various reasons, the automatic activation process gets interrupted. In such cases, in order to perform the activation, our dear colleagues should utilize an Application to obtain the activation code and manually register it.

After downloading and installing the Application from [EN.FIREWALLCO.BIZ](https://en.firewallco.biz) open Settings menu and select the Device Activation Key option.

You can see three sections in the opened window:

1. Device serial number: You can see the serial number of the device on the display after adding the first number, which includes an English letter and 15 digits. Serial number example: 123456789456789 and an English letter (V, U, etc.)

2. ADMIN SIM card number

3. SIM card number of the device

Afterward, click the Confirm button so a 6-digit code is displayed.

After entering the activation key, the device will restart.

By entering the activation code into the device, the warranty is registered, and device activation becomes complete.

Important activation tip and **warranty terms and conditions**

The warranty will be void if the products are installed by anyone except verified security system technicians, or by using non-standard equipment.

After the setup process is completed, in order to register and activate your warranty, send the installing technician's number to the company and wait for the confirmation SMS.

Contents

Device installation	4
Device features	5
1-Status indicator lights	6
1-1- AC	6
1-2- BAT	6
1-3- TEL	6
1-4- GSM	6
1-5- ARM	6
1-6- S.ARM	6
1-7- ALARM	7
1-8- LED1, LED2, ..., LED8	7
2- Persian display	7
3- Keyboard	7
4- Input/output terminals of the device	7
4-1- IN1-, IN2-, ..., IN6	7
4-2- IN7+, IN8+	8
4-3- INT.MIC	8
4-4 EXT.MIC	8
4-5 OUT1, OUT2, ..., OUT7	8
4-6 TELEPHONE	8
4-7- +SPK -GND -SIR+	8
4-8- +BAT -GNDS -AUX+	8
5-User's access level	9
5-1- Admins password	9
5-2- Managers' password	9
6- Device configuration	10
7- Zone modes	10
7-1- Normal mode	10
7-2- Delayed mode	11
7-3- 24-hour mode	11
7-4- Ding-Dong mode	11
7-5- Hidden mode	11
8- Keyboard delay	12
9- Time of the delayed zone	12
10- Triggering model of the caller	13
10-1- Edge Trigger	13
10-2- Level Trigger	

Contents

11- Battery voltage and AUX output	13
12- Voice messages of the device	13
13- AC power warning	13
14- Low-battery warning	13
Device function	14
1- Remote	14
2- Keyboard	14
2-1- Controlling the Security system	14
2-2- Device setting	14
3- short messeging service (SMS)	15
3-1- Security system management via SMS from the managers	15
3-2- Security system management via SMS from the admin	17
4- ANDROID and IOS application	18
5- Caller	18
5-1- Audio Surveillance	18
6-Device management via caller during the trigger	19
wiring diagram	20
Emergency password reset	22
programming the device	23
1-Caller setting	23
1-1- Check, save, and delete a phone number	23
1-2- Changing city code	24
1-3- Changing country code	24
1-4- Changing the number of answering rings of the caller (landline)	24
1-5- Call and SMS test	25
1-6- Changing SIM card credit checking pattern	25
1-7- SIM card credit recharge	25
1-8- Checking the remaining SIM card credit	26
1-9- Changing the trigger mode	26
1-10- SIM card caller status	26
1-11- Landline caller status	27
1-12- Running USSD codes	27
2-Wireless devices settings	27
2-1-Remote	27
2-2-Sensor	28
3-Security system setting	29
3-1- Changing trigger audio output	29

Contents

3-2- Changing the duration of the trigger sound	30
3-3- Changing the sound of lock and unlock	30
3-4- Changing zone types	30
3-5- Changing the time of keyboard delay	31
3-6- Changing the time of the delayed zone	31
3-7- Testing the zones	31
4-Primary settings of the device	32
4-1- Time and date setting	32
4-2- Changing passwords	32
4-3- Factory reset	32
4-4- Checking the serial number of the device	32
4-5- Checking the device status	33
4-6- Update	33
5-Voice settings	33
5-1- Recording a voice	33
5-2- Checking voices	33
5-3- Deleting voices	34
6-Automatic tasks settings	34
6-1- Open and lock text messages control	34
6-2- AC power warning	34
6-3- Battery charge warning	34
6-4- Landline disconnection warning	34
6-5- GSM antenna disconnection warning	34
6-6- Telegram report	35
6-7- Reporting the remaining SIM card credit	35
7-Outputs settings	36
7-1- Permanent mode	36
7-2- Momentarily mode	36
Telegram reporting	37
1- Introduction	37
2- Activating the telegram report	37
3- Receiving device reports in a telegram group	39
4- Receiving device reports in a telegram supergroup	40
5- Receiving device reports in a telegram channel	40
6- Unsubscribing	43

Device installation

1- Before inserting the device's board, make sure to connect all the wires to the device.

2- SIM PIN CODE must be deactivated before insertion. Make sure that SIM card language is set to English.

! Make sure to insert a new SIM card in the phone. Activate the new SIM card via phone call and SMS.

3- Make sure to setup the device in a location with at least 50% signal coverage. Otherwise, weak signal alarm will be sent.

4- In order to receive the activation code, make sure to save the supervisor's mobile number in the device's primary phonebook.

! In order to receive the code sent from the server, make sure that promotional SMS are enabled, and in case of using a prepaid SIM card, make sure it has sufficient credit. Otherwise, activation code will not be received.

! If you did not receive the activation code for any reason, you can progress by installing the related Application in your smartphone and manually obtain one in the Receive Activation Code menu.

! The device must be installed at a minimum distance of 30 cm from surrounding objects. This distance is for the correct operation of the receiver and cooling of the device.

! Make sure to arrange the wires in a way that they do not pass over the board and antenna. There are several entries at the back of the device for cable routing.

! Extend the antenna to the maximum length for optimized operation of the receiver.

! In case the mobile network's signal coverage is too weak, progress by employing an external antenna.

Device features

- Zones test
- Automatic reporting of the SIM card's remaining credit
- Naming capability (wired and wireless zones, remotes, sections, outputs)
- Running USSD code
- Persian display
- Easy-access user interface and Persian speaker
- Supporting 315 MHz frequency

- SIM card and landline caller
- Eight wired zones and eight wireless zones
- Four separate controllable sections
- Coding dedicated remotes for each section
- Coding sensors in the required zone
- Notifying of the low-battery level of the H9 motion sensor and Plus-wireless shock sensor
- Coding 64 wireless sensors and 20 remotes and displaying ID and frequency
- Checking and deleting remotes and sensors as needed
- Numbering the remotes and sensors
- Reducing the wiring length of the hardwire zones using only three wires
- Connecting the sensors using + and - trigger wires

- Installing external microphones in required locations
- Separate siren and speaker outputs
- Smart battery charger circuit
- Closing free zones using a deep switch
- Hopping Remote Coding capability (non-hackable)
- Reporting the triggered zone and sensor via Persian SMS service and playing a Persian voice message
- Controlling the device through calls, SMS, application, remote, and keyboard
- Sending every report and warning via telegram (to private chat, group, and channel)
- separate 30-second messages
- Edge and Controlling the device during the trigger
- 22 call memory slots
- Recording 18 level trigger of the caller
- Five different adjustable modes: delayed, 24-hour, Ding-Dong, and hidden for each zone

- Displaying the AC power status, battery and AUX voltages, antenna level, landline status, ambient temperature, time, and date (Solar Hijri Calendar)
- Sending every operation report to the admin via Persian SMS

1- Status indicator lights:

1-1- AC: This light indicates the AC status.

Fixed red: AC is connected.

Blinking red: AC voltage is low.

Off: AC is not connected.

1-2- BAT: This light indicates the battery level.

Fixed green: The battery is fully charged.

Blinking green: The battery is charging.

Fixed red: Battery level is low.

Blinking red: The battery level is at the lowest, or the battery is defective.

1-3- TEL: When this light is on, the landline connected to the device is working.

! Please note that another light on the board examines the physical connection of the landline to the device.

1-4- GSM: This light indicates the antenna status of the mobile network.

1-5- This indicator light blinks when the device is being activated, and it will be fixed once the device is in active state (ARM).

! Please note that this indicator light will be on once all the alarm sections are active (ARM).

1-6- S.ARM: When the device is in semi-active mode (SEMI.ARM), the light stays on, and when the device in the semi-active state (activation of one section) the indicator light blinks.

Device features

! Please note that if only one part becomes active, this light turns on.

1-7- ALARM: When the device is triggered, this light turns on, and after DISARM, the light blinks to notify the user of the past trigger.

! ARM and DISARM the device to wipe the ALARM memory.

1-8- LED1, LED2, ..., LED8: These indicator lights are located on the device's board, and by triggering each zone (open-circuit status), the corresponding light will turn on, and it will turn off once the trigger is removed.

! Please note that these lights are only intended to test the hardware circuit of the zones.

2- Persian display:

A Persian display is installed on the device door for easier access to the settings and checking the device messages.

3- Keyboard:

Use the keypad on the door to access the Settings menu, control the device and view messages.

4- Input/output terminals of the device:

4-1- IN1-, IN2, ..., In6-: Wired Zone 1-6 support negative-trigger sensors.

! Please note that these zones operate in NC mode, and to close each one, you must turn the related dipswitch to the ON position.

Device features

4-2- IN7+, IN8+: Wired Zone 7-8 support positive-trigger sensors.

❗ Please note that these zones operate in NC mode, and to close each one, you must turn the related dipswitch to the ON position.

4-3- INT.MIC: The microphone on the device door is connected to the device through this connector.

4-4- EXT.MIC: This connector can be used for audio surveillance in particular locations using a wired microphone.

❗ Please note that when an external microphone is connected to the device, the microphone on the device door will be disconnected from the circuit.

❗ External Microphone jack only supports 2.5MM Mono plugs.

4-5- OUT1, OUT2,..., OUT7: The F10 model has seven separate outputs to control the required electronic devices.

❗ The outputs are controlled by a relay and they support direct connection of 220 V AC electrical devices with a maximum current of 7 Amperes. In case a higher current is required, please install a contactor.

❗ The outputs are programmable to function as permanent or momentary.

4-6- TELEPHONE: This socket can be used to connect the landline to th

4-7- +SPK -GND -SIR+: You can use the +SPK- connector to connect an external speaker and the GND +SIR connector to connect a siren.

4-8- +BAT -GNDS -AUX+: You can use the +BAT GND connector to connect a backup battery. You can use the GND AUX+ connector to supply the required power for accessories.

Device features

❗ The charging circuit is protected with a 4A fuse, and the AUX power supply is protected by a 0.5A fuse.

❗ In case the fuse is broken, the AUX failure notification will be sent.

5- Users' access level:

The device has five separate passwords to control and program the functions.

5-1- Admins password: The admin is the primary user of the device who can control every part of the device using the password; the admins can also enter the device settings and program the functions. Furthermore, the reports of device operations will be sent to the admin.

❗ The device can have a maximum of four admins (memory slots 1 to 4).

❗ The default password of all admins is 000000.

❗ The supervisor's mobile number must be saved in the primary phonebook of the mobile device.

5-2- Managers passwords: The device has four separate passwords for the managers using which they can control their sections.

❗ Managers can control keyboard, telephone, SMS and device software using their passwords.

❗ Managers cannot access the device setting menu.

❗ The default passwords of the managers are 111111 (manager 1), 222222 (manager 2), 333333 (manager 3), and 444444 (manager 4).

❗ Visit the main settings section to change each of the passwords.

Device features

ACCESS LEVEL	PART1	PART2	PART3	PART4	SETTINGS	DEFAULT PASSWORD
ADMIN	✔	✔	✔	✔	✔	000000
MANAGER 1	✘	✘	✘	✘	✔	111111
MANAGER 2	✘	✘	✘	✔	✘	222222
MANAGER 3	✘	✘	✔	✘	✘	333333
MANAGER 4	✘	✔	✘	✘	✘	444444

6- Device configuration:

The alarm device supports 8 zones, each divided into 4 sections. Therefore, each of the sections consist of two zones which can be controlled with 4 independent managers and 4 supervisors.

! The admins can control every section, and managers can only control their specific section.

! In case all the sections are active, the ARM light is on. In case some of the sections are active, the S.ARM light is on.

ZONE	ZONE1	ZONE2	ZONE3	ZONE4	ZONE5	ZONE6	ZONE7	ZONE8
SECTION	SECTION1		SECTION2		SECTION3		SECTION4	

7- Zone modes:

Each zone of the security system can be set to different modes:

! Enter the device setting menu to change the function of each zone.

7-1- Normal mode: If a section has a normal zone, in case of activation (SEMI.ARM/ARM) of the section, this zone can be triggered.

Device features

7-2- Delayed mode: In case a section has a delay zone, when the section is activated (SEMI.ARM/ARM), the delay zone can be triggered with delay.

❗ The delay period of the delayed zone is programmable in the menu of the security system.

❗ This method can be used to deactivate the alarm device without using the remote. Users would have sufficient time to deactivate the device using the keyboard after entering the location.

7-3- 24-hour mode: If a section has a 24-hour zone, whether the section is active (SEMI.ARM/ARM) or inactive (DISARM), the zone can be triggered similarly to the normal mode at every hour.

This zone can be employed for installing the alarm pedals or fire detectors.

7-4- Ding-Dong mode: If a section has a ding-dong zone when the section is triggered (SEMI.ARM/ARM), this zone can be triggered similarly to the normal mode, and if the section is not active (DISARM), a ring tone would be played.

❗ This mode can be used to notify the user of the entry of unknown individuals.

❗ This zone can be employed for installing a magnet on the front door.

7-5- Hidden mode: If a section has a hidden zone when the section is active (SEMI.ARM/ARM), this zone can be triggered like a normal zone, and if the section is inactive (DISARM), the section can be triggered without activating the loudspeaker or siren, it only calls the numbers of the memory slots 21 and 22 (hidden) and plays the relevant voice message.

Device features

! This mode can be used for connecting a foot pedal or fire and smoke detector.

	NORMAL MODE	DELAYED MODE	24-hour mode	Ding-dong mode	Hidden mode
ZONE IN ARM MODE	ACTIVE	ACTIVE WITH DELAY	ACTIVE	ACTIVE	ACTIVE
ZONE IN DISARM MODE	INACTIVE	INACTIVE	ACTIVE	PLAYS RINGTONE	ONLY CALLS MEMORY SLOTS 21 AND 22

8- Keyboard delay:

Keypad delay is the time during which the user, when activating ARM/SEMI-ARM via the keypad on the main kit, has the opportunity to leave the premises. This time interval is adjustable.

! Users can use this mode to activate/semi-activate (SEMI.ARM/ARM) the device without the remote.

! Check the settings menu of the device to change the delay time of the keyboard.

9- Time of the delayed zone:

The time of the delayed zone is for the zones set with delays. After activating the relevant section and the passage of time, the distance of the delayed zone becomes active. The delay time is programmable.

! Users can use this mode to deactivate (DISARM) the system without a remote, as the users have sufficient time to deactivate (DISARM) the device using the keyboard after entering the location.

! In order to change the delay zone time, refer to the Settings menu of the Firewall alarm device.

10- Triggering model of the caller:

After the alarm is triggered, the dialer will start calling and sending SMS to all the phone numbers saved on the phonebook.

Device features

10-1- Edge trigger: In this mode, after deactivating (DISARM) the device, the caller calls every phone number added to the contact list.

10-2- Level trigger: In this mode, deactivating the device (DISARM) stops the caller from calling the contacts.

! Use the caller setting to change the triggering model.

11- Battery voltage and AUX output:

The user can check the exact voltage of the device battery, the AUX outlet, and the power status of the device.

! See the primary setting menu of the device to check the mentioned parameters.

12- Voice messages of the device:

Each wireless, wired, hidden and continuous zone can independently record 30 seconds of audio which will be replayed during the phone call once the alarm is triggered.

There is a default voice message for every wired and wireless zone that announces the triggered zone.

13- AC power warning:

The device can warn about AC power in three conditions: AC connected, AC disconnected, and low voltage. The urban electricity alarm notification will be sent to the supervisor.

14- Low battery warning:

In case the electricity is disconnected and the battery has low charge, a Low Battery notification will be sent to the supervisor.

Device function

1- Remote:

The admin and the manager can only use the remote to control the security system.

Remote key	A	B	C	D	E
Admin remote	Activating every section	Deactivating every section	Activating Section 1	Activating Section 2	Activating Section 3
N-section manager remote	Activating Section N	Deactivating Section N

- !** The user cannot separately activate section 4 using the admin remote.
- !** The user cannot separately deactivate (DISARM) any section using the admin remote.
- !** All sections can be deactivated by pressing the B button.

2. Keyboard:

2-1- Controlling the security system:

Controlling Operation	Command
Activate every section	ARM _ 000000
Deactivate every section	DISARM _ 000000
Activate one section	S.ARM _ 000000 _ DN or Up _ ENT>
Activate section N	S.ARM _ NNNNNN
Deactivate section N	DISARM _ NNNNNN

- !** NNNNNN stands for the password of the manager of section N.
- !** 000000 stands for the admin password.

2-2- Device setting:



Device function

First, open the keypad lock to enter the device setting menu.

After opening the keyboard lock, use keys UP or DN to select the intended menu.

Use the ENT key to enter the intended menu and adjust the required settings.

Programming operation	command
Opening the keyboard lock/entering the settings menu	MENU _ 000000
Navigating through the menu/Change	DN or UP
Select/enter the intended menu	ENT>
Return to the previous menu/Show device info	MENU
Deleting the last digit	CLR<
Lock the keyboard	MENU _ CLR<

! Only the manager can unlock the keypad and enter the Settings menu.
after entering any menu, pay attention to the guide below the display.

! After entering each menu, read the guide on the display.

! You can change the intended mode in the selected menus using the UP or DN keys, then select or save the modes using the ENT> key

3. Short Messaging Service (SMS):

Users can control and program the security system by sending SMS to the SIM card inserted in the device. Please note that managers can only send some of the commands.

3-1- Security system management via SMS from the managers

Device function

Command	SMS text (type the command without space)
Change device password	*NNNNNN* 88 * New password *#
Activate the security system	*NNNNNN* 11 #
Deactivate the security system	*NNNNNN* 10 #
Check the security system	*NNNNNN* 12 #
Charge SIM card credit	*NNNNNN* 98 Primary charge pattern 98 #
Check the remaining SIM card credit	*NNNNNN* 140 #
Check the device status	*NNNNNN* 00 #
Activate the output	*NNNNNN* 21 #
Deactivate the output	*NNNNNN* 20 #
Check the output	*NNNNNN* 22 #

- ❗ NNNNNN stands for the password of the section N manager,
- ❗ It is not necessary to save the managers' phone numbers in the device contact list.

Device function

3-2- Security system management via SMS from the admin

Command		SMS text (type the command without space)
Change device password	Change admin password	* 000000 * 80 * New password * #
	Change Section N manager's password	* 000000 * 8N * New password * #
Activate the security system	Activate all sections	* 000000 * 11 #
	Activate section N	* 000000 * 11 * N #
Deactivate the security system	Deactivate all sections	* 000000 * 10 #
	Deactivate section N	* 000000 * 10 * N #
Check the security system	Check every section	* 000000 * 12 #
	Check section N	* 000000 * 12 * N #
Activate the output	Activate every output	* 000000 * 21 #
	Activate output N	* 000000 * 21 * N #
Deactivate the output	Deactivate every output	* 000000 * 20 #
	Deactivate output N	* 000000 * 20 * N #
Check the output	Check every output	* 000000 * 22 #
	Check output N	* 000000 * 22 * N #
Save phone number		* 000000 * 66 * Slot number * phone number #
Check phone number		* 000000 * 55 * Slot number #
Delete phone number		* 000000 * 44 * Slot number #
Change the SIM card credit charging pattern		* 000000 * 99 SIM card credit request pattern 99 #
Charge SIM card credit		* 000000 * 98 Primary SIM card charge pattern 98 #
Check the remaining SIM card credit		* 000000 * 140 #
Check the device status		* 000000 * 00 #

! Users must save the admin's phone number in slots 1 to 4 of the device's contact list.

Device function

! 000000 stands for the admins' password.

! N stands for the section's number.

4- ANDROID and iOS application:

Users can conduct every SMS operation using the application.

In new models, there is an added naming capability (wired zones, wireless zones, remotes, sections, and outputs), which is also programmable using the iOS and ANDROID application (setting menu).

5- Caller:

Users can remotely control the security system by calling the landline connected to the device or by calling the number of the SIM card inserted in the device, according to the voice menu played by the system.

! It is not necessary to save the caller's phone number in the contact list of the device to control the security system using calls.

! The admin and the managers can separately control the device using their passwords.

! After entering the password digits, if the password is correct, a beep tone will be played; otherwise, press the intended key again to hear the confirmation beep.

! Wait for the played message to finish before pressing the intended key.

5-1- Audio surveillance:

Call the phone number of the device and press 4 after entering the password to listen to the sound captured by the microphone. The device will record the sound for approximately four minutes and then disconnect the call. If the user requires longer

Device function

surveillance, repeat the steps.

! It is recommended to call the landline connected to the device for audio surveillance.

6- Device management via caller during the trigger:

Once triggered, the alarm device starts calling and sending SMS to the phone numbers saved on the device's phonebook. When hearing the alarm for a triggered zone, by pressing the 5 button you can prevent the device from calling other numbers, and if necessary, you can control the alarm device.

! When triggered in active/semi-active (SEMI.ARM/ARM) modes, the system will not call the contacts stored in slots 21 and 22 (hidden) of the contact list.

Wiring Diagram

- !** The user must set the dipswitches of the wired zones not in use to the ON position.
- !** Dipswitches are at the ON position by default.
- !** When using the zones, the user must set the related dipswitch to the OFF position.
- !** The users can install the sensors in the required zones according to the guide.

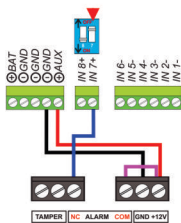

Connecting a sensor with wire individually using the positive trigger (zones 7 and 8)

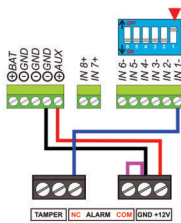

Connecting a sensor with wire individually using the negative trigger (zones 1 to 6)

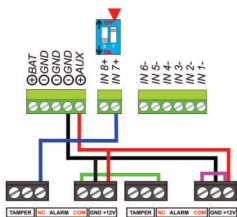

Connecting a series of sensors with wire using the negative trigger (zones 7 and 8)

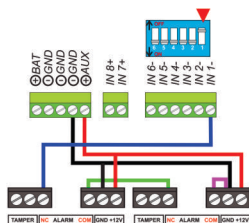

Connecting a series of sensors with wire using the negative trigger (zones 1 to 6)

Wiring Diagram

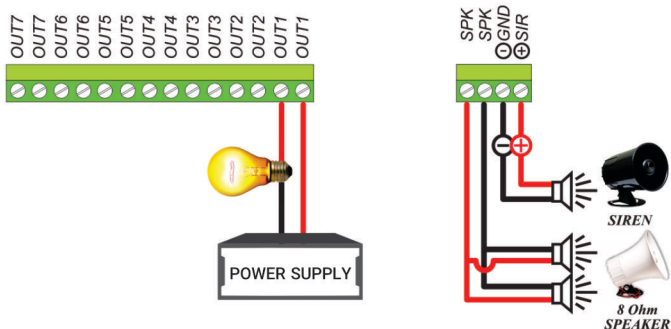

❗ Make sure to insert a new SIM card into the device and activate it via phone call and SMS.

❗ Deactivate the PIN code of the SIM card inside the device.

❗ Make sure the SIM card's language is set to English.

MTN Irancell: *555*4*3*2# MCI: *198*2#

❗ Do not block the advertising messages of the SIM card inserted in the device (To receive the activation message from the server using the inserted SIM card).

❗ When using SIM card, cancel the ringback music.

Note: We recommend the users use MCI (Hamrahe Avval) SIM cards to optimize the security system's caller function.

Wiring Diagram

Emergency password reset:

If the user forgets the passwords, resetting passwords using the following method will return them to the default.

- 1- Disconnect the power and battery of the device and wait for 20 seconds.
- 2- Press the CLR< key and reconnect the power and battery of the device.
- 3- Release the CLR< key after observing the following message.

Passwords were reset to default.

! This method will only reset the passwords to the default. Users can reset the entire settings of the device using the primary settings menu.

Programming the device

1- Caller setting:

1-1- Check, save, and delete a phone number: 1-1-1- Enter the caller setting menu;

1-1-2- Select the contact list menu;

1-1-3- Select the intended slot number using the UP and DN keys;

1-1-4- Press ENT> key;

1-1-5- Conduct the required operation using the following guide:

Operation	Command
Save/Edit the phone number in the slot	ENT> - Phone number _ ENT>
Delete the phone number saved in the memory	CLR<

❗ When triggered, the device only sends messages to numbers saved in slots 1 to 10.

❗ When triggered, the device only calls numbers saved in slots 11 to 20.

❗ In order to make sure that the device calls and sends SMS to the intended individual after being triggered, the number of the individual must be saved in both places.

❗ Users can also conduct the mentioned operations using short messages or the application.

❗ Users must save the phone numbers with the zero (Example: 09193779711).

❗ Users must save the local landline numbers where the device is installed without the city code (Example: 66887100).

❗ Users must save the landline numbers outside the area with the city code (Example: 02166842811).

« Programming the device »

! Users must use the * character for saving emergency numbers such as 110 and 125 (Example: *110).

1-2- Changing city code:

1-2-1- Enter the caller setting menu; 1-2-2- Select the city code menu;

1-2-3- Enter the city code of the installation location; press ENT>;

! If the device is installed in cities other than Tehran, the user must change the default city code.

! The default city code and city code after factory resetting the device is 021.

! The user must enter the city code with the zero (Example: 021).

1-3- Changing country code:

1-3-1- Enter the caller setting menu; 1-3-2- Enter the country code menu;

1-3-3- Enter the country code of the installation location; press ENT>;

! If the device is installed out of Iran, the user must change the country code.

! The default country code after factor resetting the device is 098.

! The user must enter the country code with the zero (Example: 098).

1-4- Changing the number of answering rings of the caller (landline):

1-4-1- Enter the caller setting menu;

1-4-2- Select the menu 'number of answering rings';

1-4-3- Select the number of intended answering rings using the keys UP and DN; press ENT>;

! The number of selected answering rings is for the landline caller.

! The number of answering rings for the inserted SIM card is two by default and

unchangeable by the user.

1-5- Call and SMS test:

1-5-1- Enter the caller settings menu; 1-5-2- Select the call and SMS test menu;

1-5-3- Select the intended memory slot number using the keys UP and DN; press ENT>;

❗ By selecting the slots 1 to 10, the device sends a message to the intended number.

❗ By selecting the slots 11 to 22, the device calls the intended number.

❗ When testing the calling ability, the user can select whether the device uses the connected landline or the inserted SIM card.

1-6- Changing SIM card credit checking pattern:

In order to check the credit of the prepaid SIM cards, the command code related to the specific mobile operator must be saved in the device. The user will be informed about the amount of credit via this command code.

1-6-1- Enter the caller settings menu;

1-6-2- Select the SIM card credit checking menu;

1-6-3- Enter the SIM card credit checking pattern; press ENT>;

❗ The default SIM card credit checking pattern is *141*1# (for MTN Irancell SIM cards).

❗ The user can also conduct the operation via SMS or application.

1-7- SIM card credit recharge:

1-7-1- Enter the caller settings menu;

1-7-2- Select the SIM card credit recharge menu;

1-7-3- Enter the SIM card credit recharge code according to the provided instructions by the operator; press ENT>;

Example: *141*1234567890123456#

❗ Users can also recharge the credit by sending text messages or via the application.

1-8- Checking the remaining SIM card credit:

1-8-1- Enter the caller settings menu;

1-8-2- Select the remaining SIM card credit menu; press ENT>;

❗ The remaining credit will be displayed on the LCD.

❗ Users can also check the remaining SIM card credit by sending text messages or via the application.

1-9- Changing the trigger mode:

1-9-1- Enter the caller settings menu; 1-9-2- Select the trigger mode menu;

1-9-3- Select the required trigger mode using the keys UP and DN; press ENT>;

❗ Edge triggering is the default trigger mode of the system.

1-10- SIM card caller status:

1-10-1- Enter the caller settings menu;

1-10-2- Select the GSM network control menu;

1-10-3- Select the required mode using the keys UP and DN; press ENT>

! If the user deactivates the SIM card caller, the device will no longer be able to send and receive text messages and calls from the SIM card.

! If the user deactivates the SIM card caller, the device will no longer be able to display the time, date, and serial number of the device.

1-11- Landline caller status:

1-11-1- Enter the caller settings menu; 1-11-2- Enter the landline controller menu;

1-11-3- Select the required mode using the keys UP and DN; press ENT>;

! If the user deactivates the landline caller, the device will no longer be able to make any calls using the landline.

1-12- Running USSD codes:

1-12-1- Enter the caller settings menu; 1-12-2- Select the USSD code running menu;

1-12-3- Enter the required USSD code; press ENT>;

2- Wireless devices settings:

2-1- Remote:

2-1-1- Coding the remote:

2-1-1-1- Enter the wireless devices settings menu;

2-1-1-2- Enter the remote menu; 2-1-1-3- Select the coding the remote menu;

2-1-1-4- Select the required level using the UP and DN keys; press ENT>;

2-1-1-5- Press and hold one of the keys on the remote.

! Press and hold a remote key close to the device.

! The user can define remotes for each section (manager) or all the sections (admin) separately in the required number.

« Programming the device »

- ❗ Check the remote section of the device function menu to understand the difference between the function of the manager's (one section) remote and the admin's (every section) remote.
- ❗ This device is compatible with 315MHz remotes and Hopping Code.
- ❗ The device has the capability of being set with 20 different remote controls, which are sequentially numbered.

2-1-2- Checking and deleting remotes:

2-1-2-1- Enter the wireless devices settings menu; 2-1-2-2- Enter the remote menu;

2-1-2-3- Enter the deleting remotes menu;

2-1-2-4- Select the required remote using the UP and DN keys; press CLR<;

2-2- Sensor:

2-2-1- Coding sensor:

2-2-1-1- Enter the wireless devices settings menu; 2-2-1-2- Enter the sensor menu;

2-2-1-3- Select the coding sensor menu;

2-2-1-4- Select the intended zone using the UP and DN keys; press ENT>;

2-2-1-5- Press and hold the sensor's test key or trigger the intended sensor. Before coding the wireless sensor, first, ensure the arrangement of the jumpers, then follow the provided protocol. In order to do this, D series jumpers must be arranged in the following formats the D1 jumper in Low mode, and jumpers D0, D2, and D3 must be blank. Additionally, A0-A7 Series jumpers must be arranged as desired and must not be left blank.

Programming the device

Note: In H9 sensors and + shock sensors, it is not necessary to adjust the D-series (D0, D1, D3) jumpers.

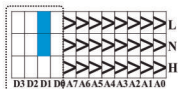

A8	A9	A10	A11
D3	D2	D1	D0

- ❗ Keep the sensor close to the device.
- ❗ Use the sensor coding menu to code the wireless equipment, including magnets, eyes (motion sensors), shock sensors, and smoke detectors.
- ❗ Sensors will be numbered following their coding order.
- ❗ Sensors working on 315MHz frequency are compatible with the device.
- ❗ Users can select the zone of the coded sensors from the menu, and it is independent of the arrangement of the jumpers.
- ❗ The device can code a total of 64 individual sensors. For coding an indefinite number, the user must arrange the sections jumpers (A0~A7) and (D0~D3) according to one of the coded sensors.

2-2-2- Checking and deleting sensors:

2-2-2-1- Enter the wireless devices settings menu;

2-2-2-2- Enter the sensor menu; 2-2-2-3- Select deleting a sensor menu;

2-2-2-4- Select the intended sensor using the UP and DN keys; press CLR<;

3- Security system setting:

3-1- Changing trigger audio output

If any of the activated sections is triggered, the speaker output and siren will become active. To change the trigger audio output, the user must follow the provided steps:

« Programming the device »

3-1-1- Enter the security system settings; 3-1-2- Select the trigger audio setting;

3-1-3- Select the intended mode using the UP and DN keys; press ENT>;

! The user can program the trigger audio as the siren, external loudspeaker, or both.

3-2- Changing the duration of the trigger sound:

3-2-1- Enter the security system settings menu;

3-2-2- Select the trigger sound duration menu;

3-2-3- Select the required time using the UP and DN keys; press ENT>;

! Note that the selected duration will be applied for the siren and the loudspeaker (both).

! The duration of the trigger sound is programable between 2 to 7 minutes.

3-3- Changing the sound of lock and unlock:

The device makes a sound when Activating/Deactivating. In order to change this sound, you must follow the instruction below.

3-3-1- Enter the security system settings menu;

3-3-2- Select the lock and unlock sound menu;

3-3-3- Select the intended mode using the UP and DN keys; press ENT>;

! The lock and unlock voice output is programmable to the siren, external speaker, internal speaker, or particular combinations of them.

3-4- Changing zone types:

3-4-1- Enter the security system settings menu;

3-4-2- Select the changing zone types menu;

3-4-3- Select the required zone using the UP and DN keys; press ENT>;

3-4-4- Select the required mode using the UP and DN keys; press ENT>;

! Note that changes in one zone simultaneously affect the wired and wireless zones.

! Visit the device features section to learn more about the different zone modes.

3-5- Changing the time of keyboard delay:

3-5-1- Enter the security system settings menu;

3-5-2- Select the keyboard delay menu;

3-5-3- Select the required period using the UP and DN keys; press ENT>;

! Visit the device features section to learn more about the applications of keyboard time.

3-6- Changing the time of the delayed zone:

3-6-1- Enter the security system settings menu;

3-6-2- Select the time of the delayed zone menu;

3-6-3- Select the required period using the UP and DN keys; press ENT>;

! Visit the device features section to learn more about the applications of delayed zones.

3-7- Testing the zones:

3-7-1- Enter the security system settings menu;

3-7-2- Select the testing the zones menu;

3-7-3- Triggering the intended sensor;

! This option is for testing the wireless and wired sensors. After triggering, the number of the intended zone and sensor will be displayed on the LCD.

4- Primary settings of the device:

4-1- Time and date setting:

4-1-1- Enter the primary settings menu of the device;

4-1-2- Select the time and date menu; 4-1-3- Enter the time and date; press ENT>;

! Note that you must enter the date in Solar Hijri calendar format.

4-2- Changing passwords:

4-2-1- Enter the primary settings menu of the device;

4-2-2- Select the changing passwords menu;

4-2-3- Select the intended password using the UP and DN keys; press ENT>;

4-2-4- Enter the new password; press ENT>;

4-2-5- Reenter the new password; press ENT>;

! Passwords must be 6 digits in length and only contain numbers.

! Repeated passwords are unacceptable.

! The operation results will be sent via SMS to the admin.

4-3- Factory reset:

4-3-1- Enter the primary settings menu of the device;

4-3-2- Select the factory reset menu; press ENT>; press ENT>;

! After completing the reset procedure, the device will be automatically restarted.

automatically restart.

4-4- Checking the serial number of the device:

4-4-1- Enter the primary settings menu of the device;

4-4-2- Select the device serial number menu; press ENT>;

4-5- Checking the device status:

4-5-1- Enter the primary settings menu of the device;

4-5-2- Select the device status menu; press ENT>;

! Battery voltage, AUX output and electricity status can be reviewed within this menu.

4-6- Update:

4-6-1- Enter the primary settings menu of the device;

4-6-2- Select the update menu; press ENT>; press ENT>;

! The device is updatable if the company provides a software file.

5- Voice settings:

5-1- Recording a voice:

5-1-1- Select the voice settings menu; 5-1-2- Select the voice recording menu;

5-1-3- Select the intended zone for recording the voice using the UP and DN keys; press ENT>;

5-1-4- Recording a message for up to 30 seconds; press ENT>;

! The length of audio recording is allowed between 1 to 30 seconds.

! Users can record a maximum duration of 30 seconds for each of the wired, wireless, hidden, and 24-hour modes separately.

5-2- Checking voices:

« Programming the device »

5-2-1- Enter the voice settings menu; 5-2-2- Select the checking voices menu;

5-2-3- Select the voice of the intended zone using the UP and DN keys; press ENT>;

5-3- Deleting voices:

5-3-1- Enter the voice settings menu; 5-3-2- Select the deleting voices menu;

5-3-3- Select the voice of the intended zone using the UP and DN keys; press CLR<;

 After deleting each voice, the related voice will return to the default.

6- Automatic tasks settings:

6-1- Open and lock text messages control:

The supervisor will be notified via SMS once the device activates/deactivates by a remote control.

6-2- AC power warning:

When the AC power is disconnected or connected, the device will send the related text message to the admin.

6-3- Battery charge warning:

When the battery charge is too low (lower than 11.4V), and after the full charge, the device sends the related text message to the admin.

6-4- Landline disconnection warning:

The supervisor will be notified via SMS once the telephone landline connects or disconnects to/from the device.

6-5- GSM antenna disconnection warning:

In case the GSM network disconnects for a period of 150 seconds or signal coverage falls below 25%, once the condition is restored to normal, the supervisor will be notified via SMS.

strength becomes sufficient).

6-6- Telegram report:

! Please follow the guide provided on pages AA to BB to use the features regarding the Telegram reporting.

This option includes 4 states, as follows:

1- Activation of (only locked and open) report: With this option, the device activation and deactivation messages are also sent via the Telegram app.

2- Activation of (only warning) reports: With this option, the device sends warning messages in the Telegram app.

3- Activation of (both) reports: With this option, the device sends messages of activation and deactivation of the security system and warning messages in the Telegram app.

4- Deactivating the Telegram reports: This option stops the device from sending messages in the Telegram app.

6-7- Reporting the remaining SIM card credit:

By defining this option, the device automatically reports the remaining SIM card credit via text message to the admin at 12 pm on the requested days (the default setting is once every three days) (the acceptable range is between one day and four weeks).

! The user can activate or deactivate the automatic tasks of the device from the automatic tasks menu in the device settings (except for the remaining SIM card credit reporting option).

7- Output settings:

The F10 model devices are equipped with seven relays, using which the user can control various electronic devices permanently and momentarily.

The modes are adjustable from the output settings menu.

7-1- Permanent mode:

In this mode, when the device receives the activation command for the output, the related relay becomes active and stays on until receiving the deactivation command of that output from the user.

7-2- Momentarily mode:

In this mode, the device activates the related output for the defined period in the device setting (ranging between 0.7 seconds and 90 minutes) after receiving the activation command from the user. The relay becomes inactive after the defined period.

! Controlling the outputs (activation, deactivation, and checking) is possible by using the application, sending text messages, and calling the device.

Telegram reporting

1- Introduction:

Besides receiving messages from the device through calls and texts, you can also receive messages in the Telegram app (private chat, group, and channel) without limitations.

Before using the robot, you must first introduce your device to this robot. Then, if you are willing to receive the device messages in your group and channel, add the robot to the created groups and channels.

2- Activating the Telegram report:

Please activate one of the following options in the automatic tasks menu of the device before starting to use the robot:

To receive locked and open text messages:

Option: Only locked and open

To receive warning:

Option: Only warnings

To receive both (locked and open messages and warnings simultaneously)

Option: Both

Telegram reporting

The next step after activating one of the Telegram reporting options on the device is to become a member of the device's Telegram robot.

The user can type the device name in the Search section, enter the result, and touch the Start option.

Name of the Firewall device's robot: @firewallf9_bot

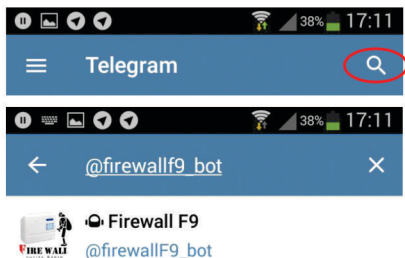

Users require the device serial number to receive the device reports through the Telegram app. Users can extract the serial number from the 'primary device settings' menu.

Users must then select the 'my devices management' in the robot.

Select the '+ add new device' option.

Enter your device serial number completely.

Example: V86211535****512 or U86211535****512

Then, a 5-digit confirmation code will be sent to the device admin's phone number.

Enter the code in the robot and wait for device confirmation inside the robot.

Telegram reporting

Note: The user must type the serial number and confirmation codes in English. After receiving the two messages, 'Device Registered Successfully' and 'Devices List,' the operation has finished, and the device will send the reports to private chat in the robot.

Use the section 'Managing my devices' for the following options:

- 1- Change the device name.
- 2- Check the list of devices connected to the robot.
- 3- Delete a device.

Users can return to the primary menu of the robot using the 'Return to previous menu' key.

3- Receiving device reports in a telegram group:

After creating a group and adding the selected users to the group, to receive the device messages in that group, enter the robot setting and add the robot to the group using the 'add group' function.

Note: Please note that all group members can see your device messages.

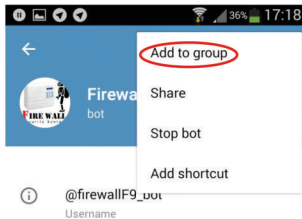

Telegram reporting

4- Receiving device reports in a telegram supergroup:

The device can also send messages to supergroups in the Telegram app. The users need to add the robot to the intended supergroup or change their normal group into a supergroup to receive the messages.

! Please note that all supergroup members can see your device messages.

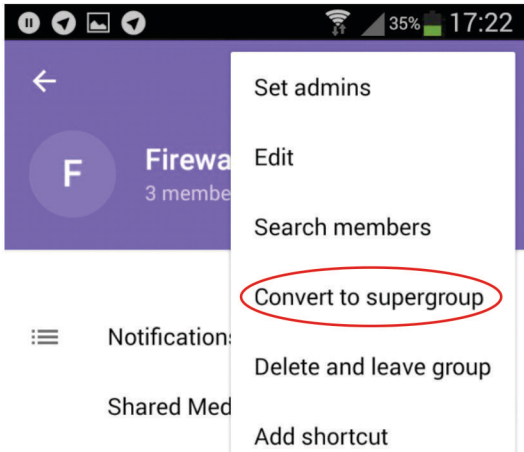

5. Receiving device reports in a telegram channel

Users need to create a channel to receive device messages in the channel. Select the 'new channel' option in the Telegram setting to create a channel. Enter your intended name and touch the accept option.

Telegram reporting

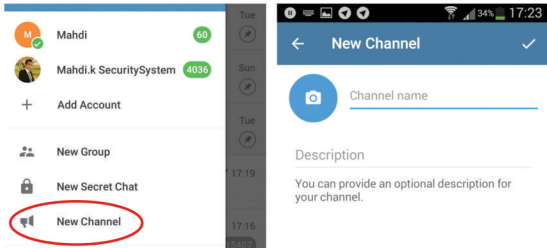

Important note: In this step, make your channel public (after finishing the steps and receiving a message in the channel, you must make it private for more safety).

Enter your channel subscription link in the 'Link' section and remember it, then touch the accept key.

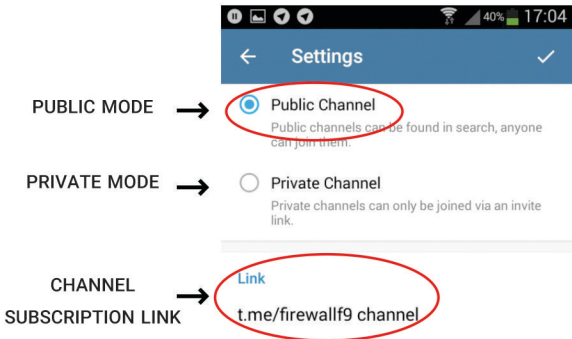

Telegram reporting

In this step, add your intended member to the channel, then touch the accept key.

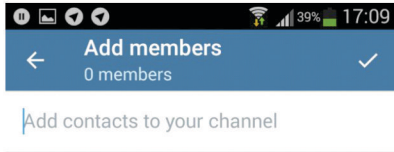

Then, enter the channel setting and add the @firewallf9_bot robot as the admin from the 'administrator' section. Make sure that the 'post messages' option must be active.

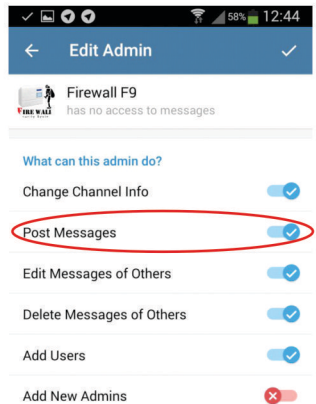
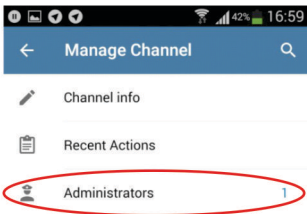
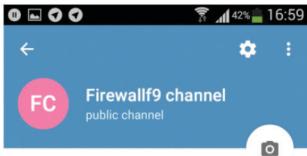

Telegram reporting

Then, enter the device robot and select the '+Register new channel' option from the channel and group management section.

Enter your subscription link. **For example:** @firewallf9 channel

After receiving the message []@firewall channel was successfully registered,[] your channel can receive the device messages.

! Please note that all the channel members can see your device messages.

Use the 'group and channel robot' section for the following options:

- 1- Creating a new channel
- 2- Checking the list of channels and groups
- 3- Deleting a channel or a group

6- Unsubscribing:

Please note that when you decide to cancel sending the Firewall device reports to the Telegram app, one of the most critical tasks that you must do is to unsubscribe from the device's Telegram robot.

You can enter the robot and touch the 'unsubscribe' option.

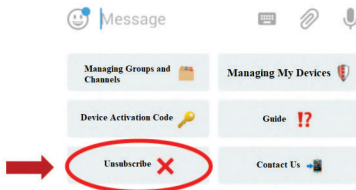

Next, deactivate the Telegram reporting from the 'automatic tasks' menu of the device



EN.FIREWALLCO.BIZ